

1

2

3

4

A

B

C

D

E

F

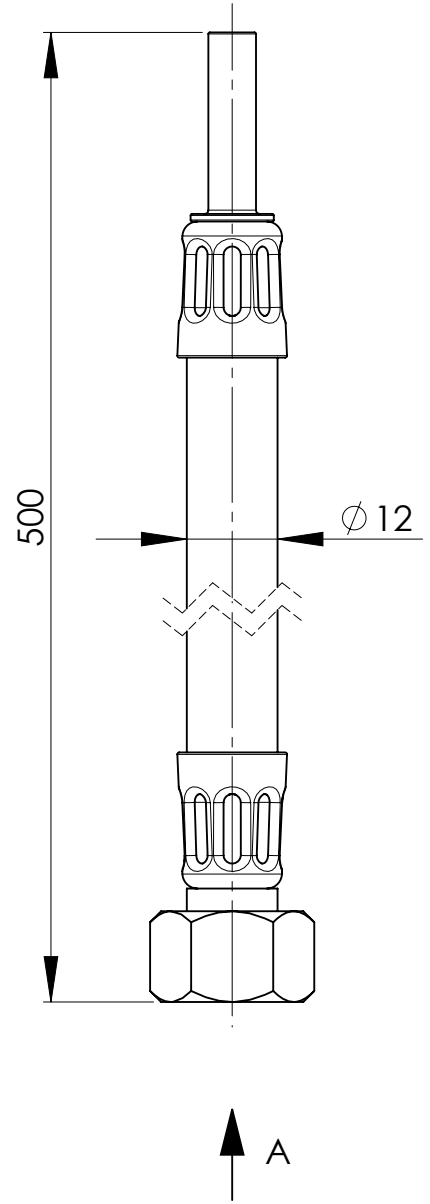
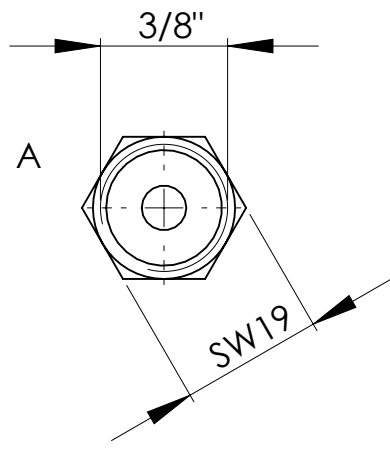
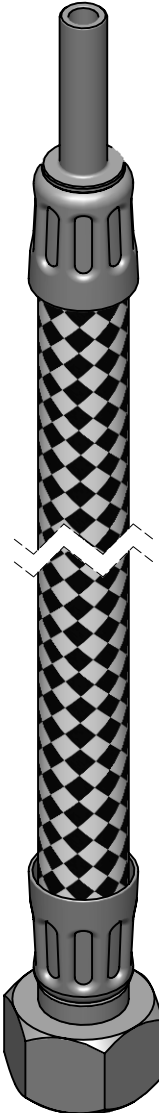

Nr. Änderungen										
Datum										
Name										

Toleranzen nach: ISO 2768-c Tolerierung DIN ISO 8015 EN ISO 13920-C ; DIN 1683 GTB 17 ; VDG P-690 D1			Werkstoff	Gewicht
	A4	Datum 08.12.2017	Name Markus Pacem	
	Artikel-Nr.: 714750007			
Maßstab 1:1	Flexschlauch 3/8" Überwurfmutter 50 cm		Zeichnungs-Nr. MP-3759	Rev. 0